

BTX-LIGHTSTRIKE

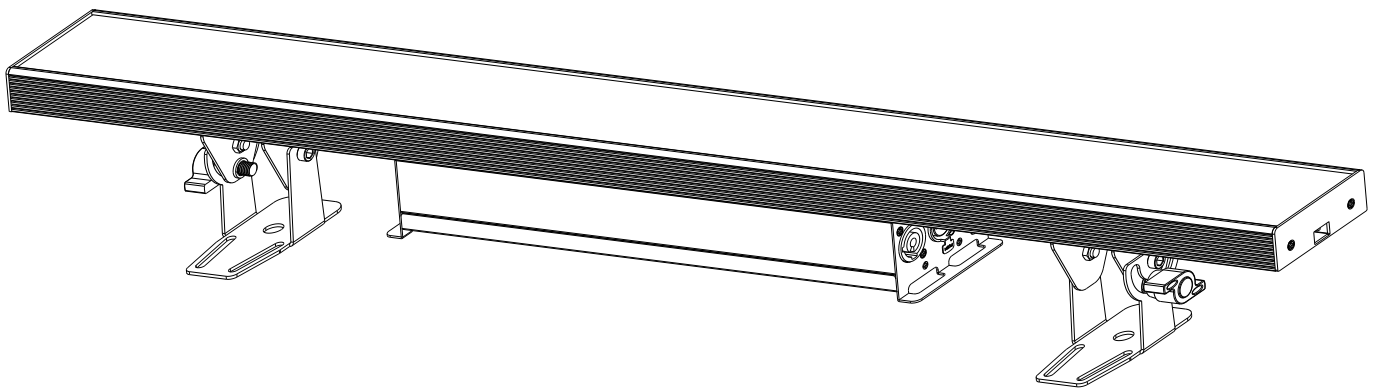

ENGLISH

Operation Manual

Other languages can be downloaded from:
WWW.BRITEQ-LIGHTING.COM



Version: 1.1 (Firmware >V1.10)





EN - DISPOSAL OF THE DEVICE

Dispose of the unit and used batteries in an environment friendly manner according to your country regulations.

FR - DÉCLASSER L'APPAREIL

Débarrassez-vous de l'appareil et des piles usagées de manière écologique Conformément aux dispositions légales de votre pays.

NL - VERWIJDEREN VAN HET APPARAAT

Verwijder het toestel en de gebruikte batterijen op een milieuvriendelijke manier conform de in uw land geldende voorschriften.

DU - ENTSORGUNG DES GERÄTS

Entsorgen Sie das Gerät und die Batterien auf umweltfreundliche Art und Weise gemäß den Vorschriften Ihres Landes.

ES - DESHACERSE DEL APARATO

Reciclar el aparato y pilas usadas de forma ecologica conforme a las disposiciones legales de su país.

PT - COMO DESFAZER-SE DA UNIDADE

Tente reciclar a unidade e as pilhas usadas respeitando o ambiente e em conformidade com as normas vigentes no seu país.

OPERATION MANUAL

Thank you for buying this Briteq® product. To take full advantage of all possibilities and for your own safety, please read these operating instructions very carefully before you start using this unit.

FEATURES

- BTX-LIGHTSTRIKE is a very versatile hybrid LED Pixel mapping bar, excellent for many rental jobs, TV-studios, concert stages, discotheques and many more.
- This hybrid LED bar consists of 2 complementary effects for maximum impact:
 - **112 extremely bright cold-white LEDs**, divided into 16 zones, form a central line to create awesome and overwhelming strobe effects.
 - **672 RGB LEDs** on both sides of the central white strobe line, arranged in 32 powerful LED pixel zones of 21 RGB LEDs each, provide a powerful tool for creating stunning, colorful moving images.
- Multiple operating modes allow for flexible use in any setting imaginable:
 - **Extended DMX modes** with up to 123 channels where you can control each pixel individually via media servers to create the most insane images and hallucinating effects.
 - **Limited-channel DMX modes** (only 15CH) where the built-in effect macros ensure that incredibly creative shows can be built with relatively simple DMX controllers in very little time.
- Besides the standard DMX with RDM support, there is also **full support for Art-net and sACN** allowing large sets to be built up and controlled quickly and efficiently.
- The BTX-LIGHTSTRIKE is very compact and has a low weight which allows it to be quickly incorporated into all kinds of scenery.
- For easy installation, 2 mounting options are included:
 - **Tilt mounting brackets**: to which standard clamps can be added.
 - **Omega bracket bases**: for use with optional omega brackets and standard clamps.
- Equipped with an inventive **quick-release mechanism** that allows you to quickly connect and align multiple projectors.
- Standard equipped with 3pin XLR, RJ45 network and PowerCON compatible connector in/outputs for easy daisy chaining.
- Very silent operation, thanks to temperature-controlled cooling fans.
- Alphanumeric OLED-display and touch keys to select the different options in the setup menu.
- Four dimmer curves: linear, square, inverse square, S-curve

BEFORE USE

- Before you start using this unit, please check if there's no transportation damage. Should there be any, do not use the device and consult your dealer first.
- **Important:** This device left our factory in perfect condition and well packaged. It is absolutely necessary for the user to strictly follow the safety instructions and warnings in this user manual. Any damage caused by mishandling is not subject to warranty. The dealer will not accept responsibility for any resulting defects or problems caused by disregarding this user manual.
- Keep this booklet in a safe place for future consultation. If you sell the fixture, be sure to add this user manual.

Check the contents:

Check that the packing contains the following items:

- BTX-LIGHTSTRIKE (tilt brackets installed)
- 2pcs extra omega bracket base
- English operating instructions, other languages can be downloaded from our website.
- Mains power cable

SAFETY INSTRUCTIONS:



CAUTION
RISK OF ELECTRIC SHOCK
DO NOT OPEN



CAUTION: To reduce the risk of electric shock, do not remove the top cover. No user-serviceable parts inside. Refer servicing to qualified service personnel only.



The lightning flash with arrowhead symbol within the equilateral triangle is intended to alert the user to the presence of un-insulated "dangerous voltage" within the product's enclosure that may be of sufficient magnitude to constitute a risk of electric shock.



The exclamation point within the equilateral triangle is intended to alert the user to the presence of important operation and maintenance (servicing) instructions in the literature accompanying this appliance.



This Class I appliance must be earthed in order to comply with safety regulations

IP20

This appliance is protected against penetration of objects over 12mm but is not protected against dripping water, rain or splashes/jets of water.



This symbol means: indoor use only!



This symbol means: Read instructions



This symbol determines: the minimum distance from lighted objects. The minimum distance between light-output and the illuminated surface must be more than 1 meters

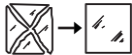

Visibly damaged lenses/housing parts should be replaced with original spare parts.



CAUTION: Do not stare at operating light source, this may be harmful to the eyes.

- To protect the environment, please try to recycle the packing material as much as possible.
- To avoid condensation to be formed inside, allow the unit to adapt to the surrounding temperatures when bringing it into a warm room after transport. Condense sometimes prevents the unit from working at full performance or may even cause damages.
- Don't place metal objects or spill liquid inside the unit. Electric shock or malfunction may result. If a foreign object enters the unit, immediately disconnect the mains power.
- Locate the fixture in a well-ventilated spot, away from any flammable materials and/or liquids. The fixture must be fixed at least 50cm from surrounding walls.
- Don't cover any ventilation openings as this may result in overheating.
- Prevent use in dusty environments and clean the unit regularly.
- Keep the unit away from children.
- Inexperienced persons should not operate this device.
- Maximum safe ambient temperature is 40°C. Don't use this unit at higher ambient temperatures.
- Make sure the area below the installation place is free from unwanted persons during rigging, de-rigging and servicing.
- Allow the device about 10 minutes to cool down before to start servicing.
- Always unplug the unit when it is not used for a longer time or before to start servicing.
- The electrical installation should be carried out by qualified personal only, according to the regulations for electrical and mechanical safety in your country.
- Check that the available voltage is not higher than the one stated on the unit.
- The power cord should always be in perfect condition. Switch the unit immediately off when the power cord is squashed or damaged. It must be replaced by the manufacturer, its service agent or similarly qualified persons in order to avoid a hazard.
- Never let the power-cord come into contact with other cables!
- This fixture must be earthed in order to comply with safety regulations.
- Don't connect the unit to any dimmer pack.
- Always use an appropriate and certified safety cable when installing the unit.
- In order to prevent electric shock, do not open the cover. There are no user serviceable parts inside.
- **Never** repair a fuse or bypass the fuse holder. **Always** replace a damaged fuse with a fuse of the same type and electrical specifications!
- In the event of serious operating problems, stop using the fixture and contact your dealer immediately.
- The housing and the lenses must be replaced if they are visibly damaged.
- Please use the original packing when the device is to be transported.
- Due to safety reasons it is prohibited to make unauthorized modifications to the unit.

Important: Never look directly into the light source! Don't use the effect in the presence of persons suffering from epilepsy.

DESCRIPTION:

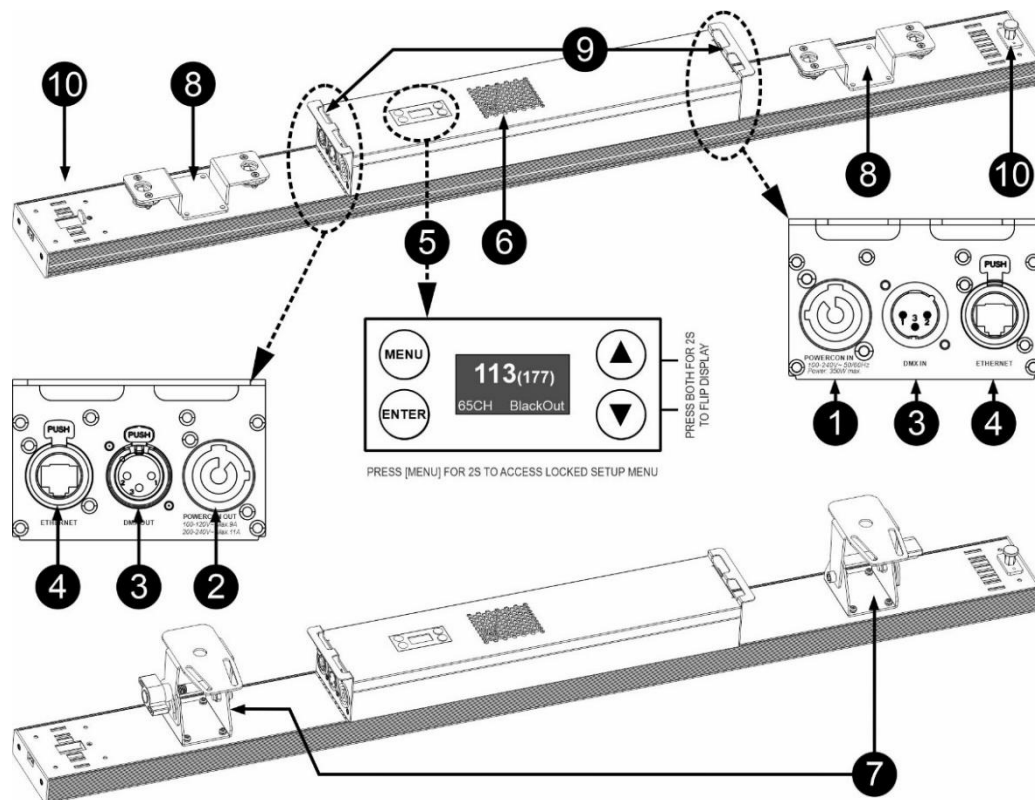

1. **MAINS INPUT:** equipped with PowerCON® compatible connectors. Connect the supplied mains cable or any PowerCon® extension cable here.
2. **MAINS OUTPUT:** used to daisy chain the power to several other projectors. Always pay attention to the maximum load while adding projectors! Special Multi cables (PowerCON® + DMX XLR-cables are optionally available: see our website!)
 - Hint: Please check our website for special cable assemblies that contain both power (3x1.5mm² with Neutrik PowerCON® TRUE1) and balanced signal (XLR 3pin) in one cable. Different lengths are available: 1.3m, 3m, 5m and 10m, very convenient!*
3. **DMX IN/OUT:** 3pin in/outputs are available to daisy chain the projector with other units that will be controlled by a DMX-controller.
4. **ETHERNET IN/OUT:** used to connect the projector to an Ethernet network, Art-Net / sACN protocol is supported.
5. **DISPLAY & BUTTONS:** alphanumeric OLED-display and touch keys to select different options of the setup menu:
 - **MENU-button:** used to browse the different menu options or to exit a menu option. If the setup menu is locked: press the button for about 2seconds to unlock and enter.
 - **▼-button:** used to go to the next menu option or to decrease a parameter value.
 - **▲-button:** used to go to the previous menu option or to increase a parameter value.
 - **ENTER-button:** used to select a menu option or confirm a setting.

Note: shortcut to flip the display → press the ▲+▼ buttons together.
6. **VENTILLATION HOLES + COOLING FAN:** it is very important to make sure that the temperature-controlled fan and ventilation openings always remain free to maintain optimal cooling!
7. **HANGING BRACKET:** with a knob to fasten the unit in the desired tilt position. You can use the hole in the center of the bracket to fix a hook or truss clamp. There are 6 fixing holes so you can adapt the position of the brackets if needed.
8. **OMEGA BRACKET BASE:** can be fixed instead of the standard hanging brackets so you can easily fix two optional “omega bracket small” (order code: B02677). There are 6 fixing holes so you can adapt the position of the omega bases if needed.
9. **SAFETY HOLE:** used to attach (an optional) safety cable when the unit is rigged, see paragraph “overhead rigging”.

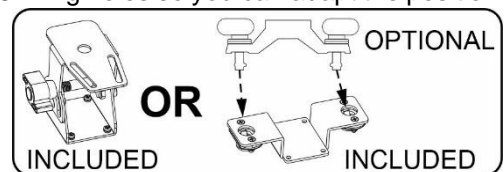

10. COUPLER MECHANISM: the coupler mechanism makes it possible to quickly connect and align two or a long line of projectors together. Please proceed as follows:

- A. Pull the locking pin and turn it over 90° so it stays unlocked.
- B. Move the latch on the other projector so that the slide comes out completely.
- C. Place both projectors nicely against each other in line so that the slide fits nicely into the other projector.
- D. When this is done, pull the locking pin and turn it again over 90°, until the pin fits in the hole of the slide and locks both projectors together.

Done!

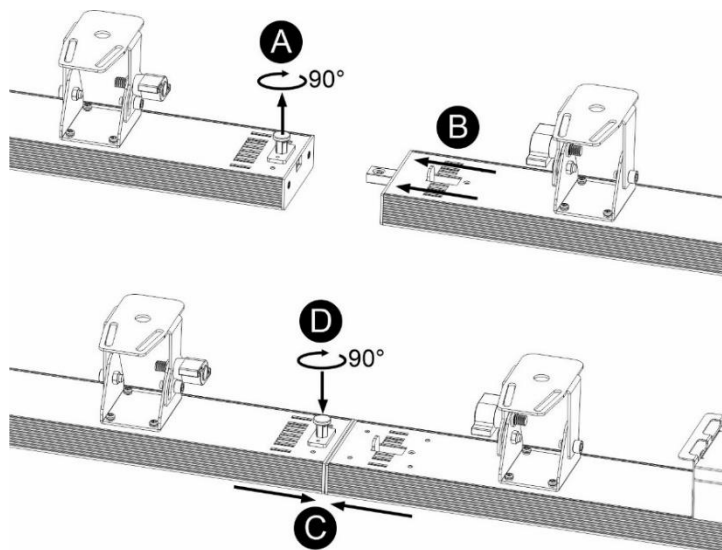

OVERHEAD RIGGING

- **Important:** The installation must be carried out by qualified service personal only. Improper installation can result in serious injuries and/or damage to property. Overhead rigging requires extensive experience! Working load limits should be respected, certified installation materials should be used, the installed device should be inspected regularly for safety.
- Make sure the area below the installation place is free from unwanted persons during rigging, de-rigging and servicing.
- Locate the fixture in a well-ventilated spot, far away from any flammable materials and/or liquids. The fixture must be fixed **at least 50cm** from surrounding walls.
- The device should be installed out of reach of people and outside areas where persons may walk by or be seated.
- Before rigging make sure that the installation area can hold a minimum point load of 10times the device's weight.
- Always use a certified safety cable that can hold 12times the weight of the device when installing the unit. This secondary safety attachment should be installed in a way that no part of the installation can drop more than 20cm if the main attachment fails.
- The device should be well fixed; a free-swinging mounting is dangerous and may not be considered!
- Don't cover any ventilation openings as this may result in overheating.
- The operator has to make sure that the safety-relating and machine-technical installations are approved by an expert before using them for the first time. The installations should be inspected every year by a skilled person to be sure that safety is still optimal.

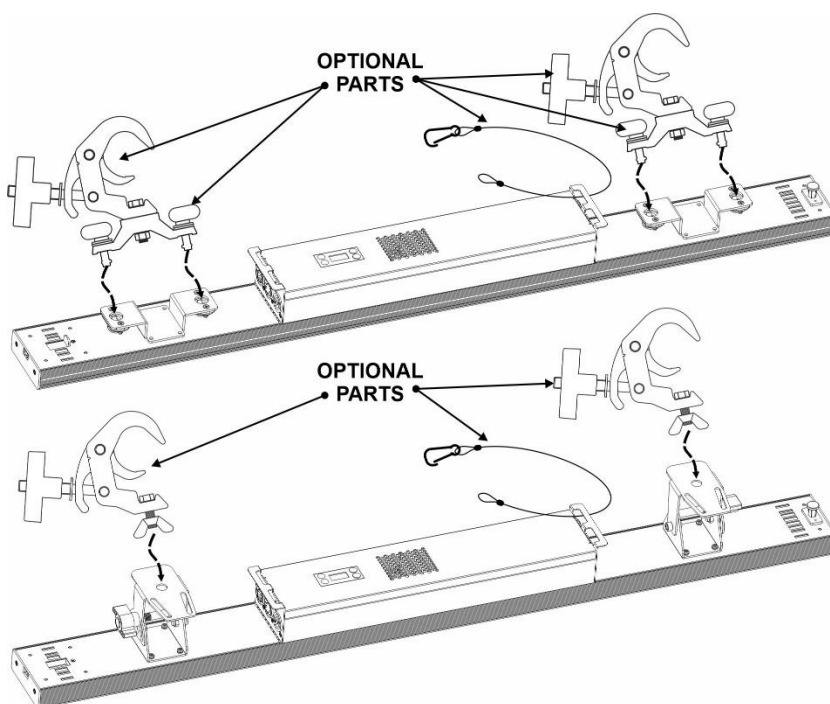

SETUP MENU:

Main Menu	1st Level	2nd Level	Remarks	Default Value	
DMX Settings	DMX Address	001 (xxx)	xxx depends on selected mode	1	
	Channel Mode	6CH			21CH
		15CH			
		17CH			
		21CH			
		33CH			
		33CH FULL	17CH mode + MACROS		
		39CH			
		49CH FULL	33CH mode + MACROS		
		65CH			
		81CH FULL	65CH mode + MACROS		
	113CH				
	123CH	113CH + DIM & STROBE			
	No DMX Status	BlackOut			Freeze
		Freeze			
	View DMX Value		Select a channel to monitor		
	Connect Option	Auto			Auto
DMX					
Art-Net					
sACN					
Network	IP Address				
	Subnet Mask				
Art-Net Settings	Net	values: 0 → 127		0	
	Sub-Net	values: 0 → 15		0	
	Universe	values: 0 → 15		0	
sACN Settings	sACN Universe	values: 0001 → 32000		1	
	sACN Priority	values: 0 → 200		100	
Fixture Settings	Dimmer Curve	Linear		Square law	
		Square law			
		Inv SQ law			
		S Curve			
	Dimmer Speed	Fast		Fast	
		Smooth			
	White Balance	Red1		255	
		Green1		255	
		Blue1		255	
		Red2		255	
		Green2		255	
	Blue2			255	
	Invert PixelOrder	DISABLE		DISABLE	
ENABLE					
PWM Frequency	3600 Hz		4800 Hz		
	4800 Hz				
	7200 Hz				
	12000 Hz				
Display Settings	Display Invert	No/Yes		No	
	Temperature Unit	°C / F	(Celcius / Fahrenheit)	°C	
Fixture Test	Auto Test				
Fixture Information	Fixture Use Hour				
	LED Use Hour	Total LED Hour			
		LED On Hour			
		LED Hours Reset	needs password (= 050)		
	Temperature		current + max LED temp.		
	Fan State	xxxx	shows actual rotation speed		
Firmware Version					
RDM UID	xxxxxx				
Error Logs	Fixture Errors				
	Reset Error Log	confirm with password (= 050)			
Special Functions	Factory Restore	No/Yes			

General operation of the setup menu:

- Press the MENU button to ENTER the setup menu.
- Press the ▼/▲ buttons to browse the menu until the required function shows up.
- Select the function with the ENTER button.
- Use ▼/▲ buttons to change the values.
- Press the ENTER button to confirm the selected value.
- Press the MENU button to return to a higher level in the menu or leave the setup menu.

Remark 1: press the MENU button during 2s to unlock the setup menu

Remark 2: press the ▼/▲ buttons together to flip the display.

DMX SETTINGS menu**DMX ADDRESS**

Used to set the desired DMX-address.

- Press the ▼/▲ buttons to browse the menu until the required function shows up.
- Press the ENTER button: the values can be changed
- Use ▼/▲ buttons to select the desired DMX512 address. The last occupied DMX-address is also shown: makes it easier to set the address of the next unit in the chain.
- Once the correct address shows on the display, press the ENTER button to save it.

Note: on RDM-compatible controllers this option can also be remotely set.

CHANNEL MODE

Used to set the desired channel mode.

- Press the ▼/▲ buttons to browse the menu until the required function shows up.
- Press the ENTER button: the values can be changed
- Use ▼/▲ buttons to select the desired mode:
 - **6CH** 2 zones: z1= RGB + z2 = WHITE (no effect macros)
 - **15CH** 2 zones: z1= RGB + z2 = WHITE + multi-zone effect macros (combined control RGB / WHITE)
 - **21CH** 2 zones: z1= RGB + z2 = WHITE + multi-zone effect macros (separate control RGB / WHITE)
 - **17CH** 8 zones: 4 RGB + 4 WHITE + Function channel
 - **33CH** 16 zones: 8 RGB + 8 WHITE (only pixel control) + Function channel
 - **33CH F** 8 zones: 4 RGB + 4 WHITE + Function channel + strobe & dim + effect macros
 - **39CH** 16 zones: 8 RGB + 8 WHITE + separate RGB / WHITE strobe & dim + Function channel
 - **49CH F** 16 zones: 8 RGB + 8 WHITE + Function channel + strobe & dim + effect macros
 - **65CH** 32 zones: 16 RGB + 16 WHITE (only pixel control) + Function channel
 - **81CH F** 32 zones: 16 RGB + 16 WHITE + Function channel + strobe & dim + effect macros
 - **113CH** 48 zones: 32 RGB + 16 WHITE (only pixel control) + Function channel
 - **123CH** 48 zones: 32 RGB + 16 WHITE (only pixel control) + strobe & dim + Function channel
- Once the correct option shows on the display, press the ENTER button to save it.

Remark: on RDM-compatible controllers this option can also be remotely set.

NO DMX Status

Used to set how the projector reacts when the DMX-signal suddenly disappears.

- Press the ▼/▲ buttons to browse the menu until the required function shows up.
- Press the ENTER button: the values can be changed
- Use ▼/▲ buttons to select the desired mode:
 - **BLACKOUT:** output turns black while no DMX is detected.
 - **FREEZE:** output based on the last valid DMX-signal is kept on the projector.
- Once the correct option shows on the display, press the ENTER button to save it.

Note: as soon as the input detects a DMX-signal, blackout or freeze mode will be cancelled.

View DMX Values

Used to monitor the incoming DMX-signals, handy for fault debugging.

- Press the ▼/▲ buttons to browse the menu until the required function shows up.
- Press the ENTER button: you can monitor the incoming DMX-signal, functions and values are displayed.
- Press the ▼/▲ buttons to select the channel that you want to monitor.

Connect Option

Used to set the desired control mode.

- Press the ▼/▲ buttons to browse the menu until the required function shows up.
- Press the ENTER button: the values can be changed
- Use ▼/▲ buttons to select the desired mode:
 - **AUTO:** checks the incoming signals and selects the first valid signal.
 - **DMX:** standard DMX / RDM input is used for control
 - **Art-Net:** Art-Net™ protocol is used
 - **sACN:** sACN protocol is used.

Network

Used to set the network parameters.

- Press the ▼/▲ buttons to browse the menu until the required function shows up.
 - IP-address
 - Subnet Mask
- Press the ENTER button: the values can be changed
- Use combination of ▼/▲ and ENTER buttons to set the desired values.

Art-Net Settings

Used to set the specific Art-Net parameters.

- Press the ▼/▲ buttons to browse the menu until the required function shows up.
 - Net (0 → 127)
 - Sub-Net (0 → 15)
 - Universe (0 → 15)
- Press the ENTER button: the values can be changed
- Use combination of ▼/▲ and ENTER buttons to set the desired values.

sACN Settings

Used to set the specific sACN parameters.

- Press the ▼/▲ buttons to browse the menu until the required function shows up.
 - sACN universe (1 → 32'000)
 - sACN priority (0 → 200)
- Press the ENTER button: the values can be changed
- Use combination of ▼/▲ and ENTER buttons to set the desired values.

FIXTURE SETTINGS menu**DIMMER CURVE**

Used to set the dimmer curve of the master dimmer.

- Press the ▼/▲ buttons to browse the menu until the required function shows up.
- Press the ENTER button: the values can be changed
- Use ▼/▲ buttons to selected the desired curve:

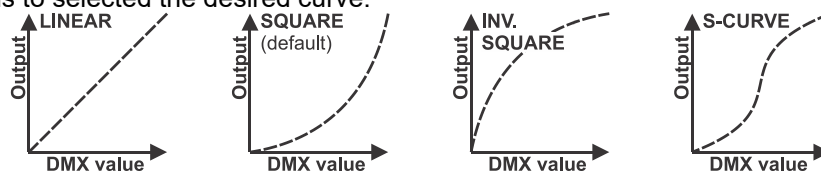

- Once you have the desired curve, press the ENTER button to save it.

DIMMER SPEED

Used to set the speed (smoothness) of the dimmer continuously.

- Press the ▼/▲ buttons to browse the menu until the required function shows up.
- Press the ENTER button: the values can be changed
- Use ▲/▼ buttons to select the desired speed:
 - **Fast:** quick and snappy response, can small steps can be noticed while dimming very slowly.
 - **Smooth:** smoother dimming without visual steps but slower reaction time for fast changes.
- Once the desired value shows on the display, press the ENTER button to confirm.

WHITE BALANCE

Used to set the white balance.

The projector contains 2 PCBs with LEDs: when 1 PCB needs to be replaced, the white balance helps to match the colors of the new PCB with those of the already present PCB. We recommend to use this option only when it is really necessary.

- Connect the projector to a DMX controller in the 6CH DMX-mode and choose the color you want to match.
- Press the ▼/▲ buttons to browse the menu until the required function shows up.
- Press the ENTER button: the display shows the 3 LED colors of PCB 1 & 2 (change with ▼/▲ buttons)
- Press the ENTER button: the display shows the value (125-255) for the selected color / led.
- Use ▼/▲ buttons to adapt the value between 125 and 255 and confirm with ENTER
- Repeat these steps until you have the desired values. The settings will be automatically saved.

Invert PixelOrder

To keep uniformity, you can flip the pixel order when some projectors are mounted normally and others upside-down (suspended).

- Press the ▼/▲ buttons to browse the menu until the required function shows up.
- Press the ENTER button: the values can be changed
- Use ▼/▲ buttons to select the desired mode:

INVERT PIXEL ORDER = DISABLE

1	2	3	4	5	6	7	8	9	10	11	12	13	14	15	16
W1	W2	W3	W4	W5	W6	W7	W8	W9	W10	W11	W12	W13	W14	W15	W16
17	18	19	20	21	22	23	24	25	26	27	28	29	30	31	32

INVERT PIXEL ORDER = ENABLE

32	31	30	29	28	27	26	25	24	23	22	21	20	19	18	17
W16	W15	W14	W13	W12	W11	W10	W9	W8	W7	W6	W5	W4	W3	W2	W1
16	15	14	13	12	11	10	9	8	7	6	5	4	3	2	1

- Once the correct option shows on the display, press the ENTER button to save it.

PWM Frequency

Used to set the PWM refresh frequency of the LED dimming to avoid undesired effects on video recordings.

- Press the ▲/▼ buttons until the desired function is showing on the display.
- Press the ENTER button: the values can be changed
- Use ▲/▼ buttons to select the desired speed:
 - 3600 Hz : slowest PWM frequency.
 - ...
 - 12000 Hz: highest possible PWM frequency,

- Once the desired value shows on the display, press the ENTER button to confirm.

Remark 1: please note that the dimmer behavior changes when the PWM frequency is changed so always use the same PWM frequency on all units.

Remark 2: The default value (4800 Hz) gives excellent results.

DISPLAY SETTINGS menu

Display Invert

Used to flip the display (turn it 180°).

- Press the ▼/▲ buttons to browse the menu until the required function shows up.
- Press the ENTER button: the values can be changed
- Use ▼/▲ buttons to select the desired mode:
 - No: normal display
 - Yes: flipped display.
- Once the correct option shows on the display, press the ENTER button to save it.

Remark: a faster shortcut is to press the ▼/▲ buttons together for about 2 seconds.

Temperature Units

Used to select if the LED-temperature is shown in degrees Celsius °C or Fahrenheit F.

- Press the ▼/▲ buttons to browse the menu until the required function shows up.
- Press the ENTER button: the values can be changed
- Use ▼/▲ buttons to select the desired mode:
 - °C: temperature shown in degrees Celsius.
 - F: temperature shown in Fahrenheit.
- Once the correct option shows on the display, press the ENTER button to save it.

FIXTURE TEST menu**AUTO TEST**

Used to quickly check if all LEDs are working well without the need for a DMX-console.

- Press the ▼/▲ buttons to browse the menu until the required function shows up.
- Press the ENTER button:
 - The display starts flashing while showing "Testing....."
 - The different LED colors are lit one by one so you can see if they are all working well.
- Press the MENU button to stop the "AUTO TEST" function.

FIXTURE INFORMATION menu**FIXTURE Use Hours**

Shows the Total time the projector was switched on, starting from the 1st day it was used.

- Press the ▼/▲ buttons to browse the menu until the required function shows up.
- Press the ENTER button: the TOTAL usage time is shown, this value cannot be reset.

LED Use Hours

Shows the time information of the LEDs in the projector.

- Press the ▼/▲ buttons to browse the menu until the required function shows up.
- Press the ENTER button → 3 options are shown:
 - **Total LED Hour:** shows the number of operating hours of the LEDs since the first use
 - **LED On Hour:** shows the number of operating hours of the LEDs since the last reset.
 - **LED Hours reset:** resets the "LED On Hour" counter.

Temperature

Shows the current + Max LED Temperature.

- Press the ▼/▲ buttons to browse the menu until the required function shows up.
- Press the ENTER button (use ▼/▲ buttons to choose the LEDs on PCB1 or PCB2):
 - The current LED temperature is shown.
 - The MAXIMUM LED temperature is shown, since the projector was switched on.

Fan State

Shows the actual rotation speed of the cooling fan.

- Press the ▼/▲ buttons to browse the menu until the required function shows up.
- Press the ENTER button: the current rotation speed is shown (in RPM)

Firmware Version

Shows actual firmware version information.

- Press the ▼/▲ buttons to browse the menu until the required function shows up.
- Press the ENTER button: the current firmware version of the different processors is shown.

Note: The firmware of this unit can be upgraded using our special "Firmware Updater" (separately available from Briteq). More information about this can be found in the user manual of the firmware updater or our website: <https://briteq-lighting.com/firmware-updater>

RDM UID

Shows actual unique RDM ID of the projector.

- Press the ▼/▲ buttons to browse the menu until the required function shows up.
- Press the ENTER button: the unique RDM ID of the projector is shown.

- This RDM-UID has 2 parts:
 - Fixed part (same for all BTX-LIGHTSTRIKE units): 21220047
 - Random part (unique 4-digit for each unit, ranging from 0000 to FFFF)

ERROR Logs

Shows eventual ERROR messages if they exist.

- Press the ▼/▲ buttons to browse the menu until the required function shows up.
 - Press the ENTER button: under normal conditions the display should be empty.
- Remark:** when a FAN ERROR occurs, the output is reduced to 50% to prevent overheating of the unit.

SPECIAL FUNCTIONS menu

FACTORY RESTORE

This is your emergency exit if you really messed up the settings: just return to factory settings.

- Press the ▼/▲ buttons to browse the menu until the required function shows up.
- Press the ENTER button: the values can be changed
- Use ▼/▲ buttons to selected the desired option:
 - No (nothing happens)
 - Yes (factory defaults are loaded)

Remark: the default values are shown in the last column of the SETUP MENU table, see earlier in this manual.

ELECTRICAL INSTALLATION



Important: The electrical installation should be carried out by qualified personal only, according to the regulations for electrical and mechanical safety in your country.

Mains power is the same for all units but there are different possibilities to connect the data cabling:

ELECTRICAL INSTALLATION FOR TWO OR MORE UNITS IN WIRED DMX-MODE:

Use this function when you want to control the projectors by any DMX controller.

- Connect the projectors as shown in the drawing below.

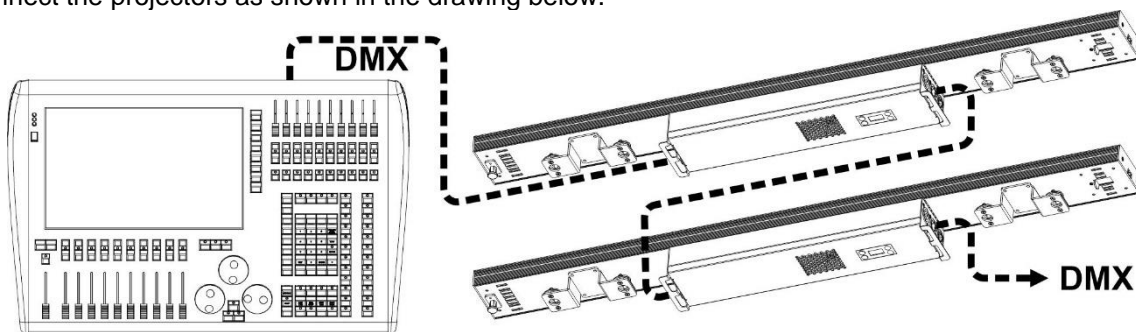

- First put the projectors in the desired DMX-mode: see the different DMX-charts and choose the one that suits you best.
- Give all projectors a start address: each projector shows its start + end address, make sure that the addresses do not overlap!

Some general information on DMX:

- The DMX-protocol is a widely used high speed signal to control intelligent light equipment. You need to “daisy chain” your DMX controller and all the connected units with a balanced cable of good quality.
- Both XLR-3pin and XLR-5pin connectors are used, however XLR-3pin is more popular because these cables are compatible with balanced audio cables.
- Pin layout XLR-3pin: Pin1 = GND ~ Pin2 = Negative signal (-) ~ Pin3 = Positive signal (+)
- Pin layout XLR-5pin: Pin1 = GND ~ Pin2 = Negative signal (-) ~ Pin3 = Positive signal (+) ~ Pins4+5 not used.
- To prevent strange behavior of the light effects, due to interferences, you must use a 90Ω to 120Ω terminator at the end of the chain. Never use Y-splitter cables, this simply won't work!

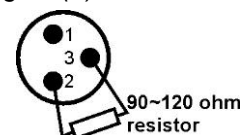

- Make sure that all units are connected to the mains.
- Each light effect in the chain needs to have its proper starting address so it knows which commands from the controller it has to decode.

ELECTRICAL INSTALLATION VIA WIRED ETHERNET IN/OUT:

Art-Net is nothing more than a protocol for transmitting DMX512 over an Ethernet network, developed by Artistic Licence Engineering (UK) Ltd. Thanks to the much bigger bandwidth it is possible to send more than 256 DMX-universes in one time.

This projector can be connected in such Ethernet network using routers, switches etc. The network topology is exactly the same as for a normal PC-network. However, IP-addresses cannot be obtained via DHCP: see the explanations in the chapter “setup menu” on how to manually setup the IP-address, Net Mask and choose the desired DMX-universe. Also the sACN protocol is supported.

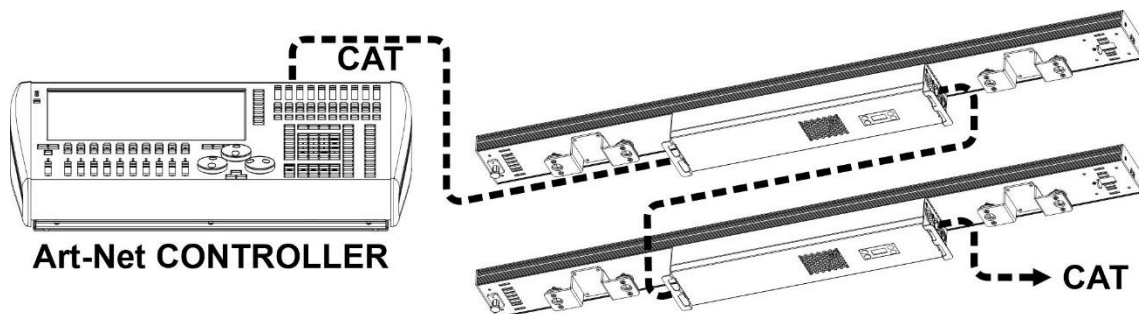

IMPORTANT NOTE: this projector has both Ethernet input and output so you can daisy chain several units. However, the number of units in one chain should be limited to ±10 units to avoid unwanted signal delays. In bigger installations you should use the “STAR-topology” using Ethernet switches (or a combination of both). This reduces the delays between unit and also improves reliability of the installation.

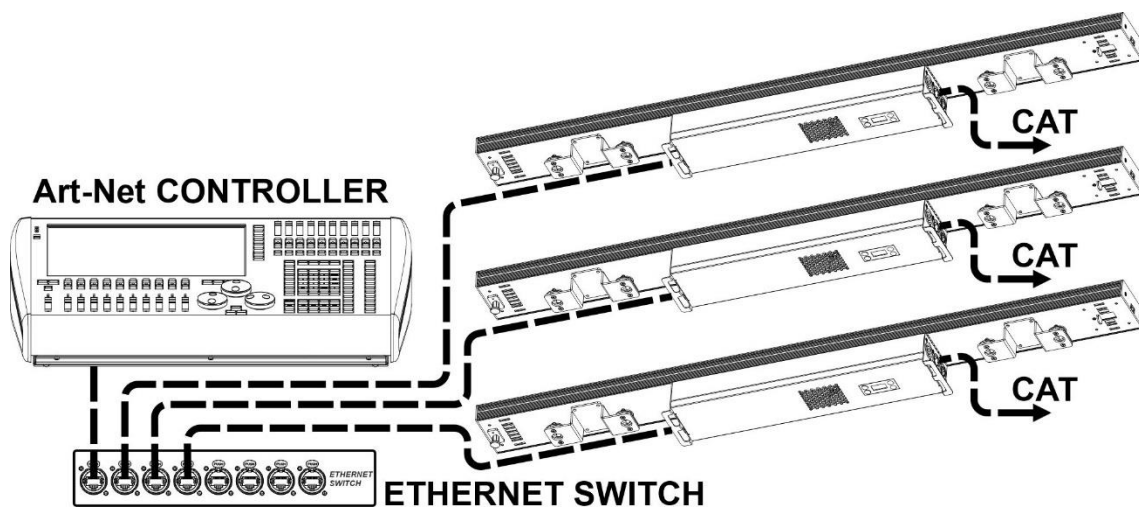

- Internally the selected DMX-universe is treated as a normal DMX-signal so further setup of the DMX-address, channel mode etc. should be done as usual.

DMX CHARTS

There are several DMX-modes for maximum compatibility under different conditions:

DMX CHART for BASIC USE

Simple mode, without pixels control or pixel macros

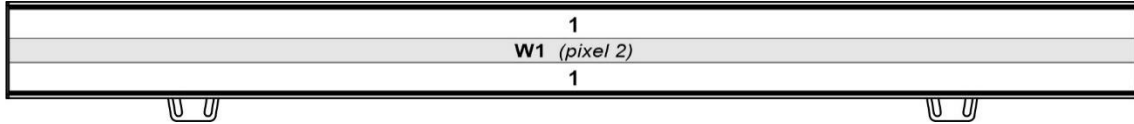

6 CH	VALUE	FUNCTION	REMARKS
1	000-255	RED	<i>pixel 1</i>
2	000-255	GREEN	<i>pixel 1</i>
3	000-255	BLUE	<i>pixel 1</i>
4	000-255	WHITE	<i>pixel 2</i>
5	000-255	MASTER DIMMER (coarse) 0 → 100%	
6	000-255	MASTER DIMMER (fine) 0 → 100%	

DMX CHARTS with pre-programmed PIXEL MACROS

Easy mode, with pixel macros: the perfect choice to make nice shows on controllers with a limited number of DMX channels or when there is not enough time to write complicated pixel mapping programs.

15CH LAYOUT

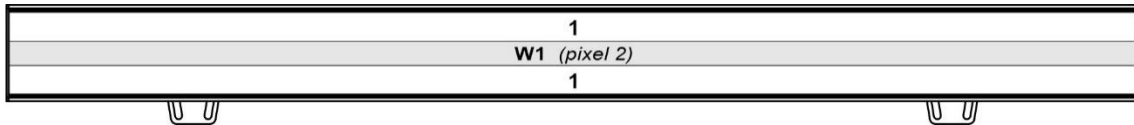

15 CH	VALUE	FUNCTION	REMARKS
1	000-255	RED	<i>pixel 1</i>
2	000-255	GREEN	<i>pixel 1</i>
3	000-255	BLUE	<i>pixel 1</i>
4	000-255	WHITE	<i>pixel 2</i>
5	MACRO COLOR PRESETS		
	000-009	Macros OFF	
	010-017	Color1	
	018-024	Color2	
	025-032	Color3	
	033-039	Color4	
	040-047	Color5	
	048-054	Color6	
	055-061	Color7	
	062-069	Color8	
	070-076	Color9	
	077-084	Color10	
	085-091	Color11	
	092-099	Color12	
	100-106	Color13	
	107-113	Color14	
	114-121	Color15	
	122-128	Color16	
	129-136	Color17	
	137-143	Color18	
	144-151	Color19	
	152-158	Color20	
	159-165	Color21	
166-173	Color22		
174-180	Color23		

	181-188	Color24	
	189-195	Color25	
	196-203	Color26	
	204-210	Color27	
	211-217	Color28	
	218-225	Color29	
	226-232	Color30	
	233-240	Color31	
	241-247	Color32	
	248-255	Color33	
6	000-255	MASTER DIMMER (coarse) 0 → 100%	<i>combined for all pixels</i>
7	000-255	MASTER DIMMER (fine) 0 → 100%	<i>16 bit mode</i>
8	000-255	STROBE DURATION	<i>combined for all pixels</i>
		STROBE SPEED	
9	000-006	No strobe	<i>combined for all pixels</i>
	007-255	SPEED (slow → fast)	<i>combined for all pixels</i>
		STROBE EFFECTS	
10	000-005	No effect	<i>combined for all pixels</i>
	006-050	Ramp up	<i>combined for all pixels</i>
	051-100	Ramp down	<i>combined for all pixels</i>
	101-150	Ramp up-down	<i>combined for all pixels</i>
	151-200	Lightning	<i>combined for all pixels</i>
	201-255	Random	<i>combined for all pixels</i>
		RGB EFFECT MACROS	<i>RGB macros use 32pixels</i>
	000-039	No function	
	040-047	RGB Macro 1	
	048-055	RGB Macro 2	
	056-063	RGB Macro 3	
	064-071	RGB Macro 4	
	072-079	RGB Macro 5	
	080-087	RGB Macro 6	
	088-095	RGB Macro 7	
	096-103	RGB Macro 8	
	104-111	RGB Macro 9	
	112-119	RGB Macro 10	
	120-127	RGB Macro 11	
	128-135	RGB Macro 12	
11	136-143	RGB Macro 13	
	144-151	RGB Macro 14	
	152-159	RGB Macro 15	
	160-167	RGB Macro 16	
	168-175	RGB Macro 17	
	176-183	RGB Macro 18	
	184-191	RGB Macro 19	
	192-199	RGB Macro 20	
	200-207	RGB Macro 21	
	208-215	RGB Macro 22	
	216-223	RGB Macro 23	
	224-231	RGB Macro 24	
	232-239	RGB Macro 25	
	240-247	RGB Macro 26	
	248-255	RGB Macro 27	
		EFFECT MACROS - WHITE CENTRAL LINE	<i>WHITE macros use 16pixels</i>
	000-090	No function	
12	091-105	WHITE Macro 1	
	106-120	WHITE Macro 2	
	121-135	WHITE Macro 3	
	136-150	WHITE Macro 4	
	151-165	WHITE Macro 5	
	166-180	WHITE Macro 6	
	181-195	WHITE Macro 7	
	196-210	WHITE Macro 8	

	211-225	WHITE Macro 9	
	226-240	WHITE Macro 10	
	241-255	WHITE Macro 11	
13		MACRO SPEED (COMBINED FOR CH11 + CH12)	
	000-004	STOP (waiting at first step)	
	005-127	SPEED L→R: SLOW to FAST	
	128-132	STOP (waiting at last step)	
	133-255	SPEED R→L: SLOW to FAST	
14	000-255	FADE EFFECT (zero → max)	
15		FUNCTION CHANNEL	
	000-005	No function	
	006-010	DIMMER CURVE: LINEAR	3 seconds delay
	011-015	DIMMER CURVE: SQUARE	3 seconds delay
	016-020	DIMMER CURVE: INV. SQUARE	3 seconds delay
	021-025	DIMMER CURVE: S-CURVE	3 seconds delay
	026-030	No function	
	031-035	DIMMER SPEED: FAST	3 seconds delay
	036-040	DIMMER SPEED: SLOW	3 seconds delay
	041-045	No function	
	046-050	PIXEL ORDER: NORMAL	3 seconds delay
	051-055	PIXEL ORDER: INVERSED	3 seconds delay
	056-065	No function	
	066-070	LED PWM Frequency: 3600Hz	3 seconds delay
	071-075	LED PWM Frequency: 4800Hz	3 seconds delay
	076-080	LED PWM Frequency: 7200Hz	3 seconds delay
	081-085	LED PWM Frequency: 12000Hz	3 seconds delay
		086-255	No function

21CH LAYOUT

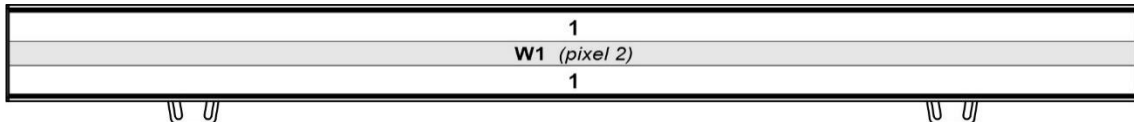

21 CH	VALUE	FUNCTION	REMARKS	
CONTROLS FOR RGB ZONES	1	000-255	RED <i>pixel 1</i>	
	2	000-255	GREEN <i>pixel 1</i>	
	3	000-255	BLUE <i>pixel 1</i>	
	4		MACRO COLOR PRESETS	
		000-009	Macros OFF	
		010-017	Color1	
		018-024	Color2	
		025-032	Color3	
		033-039	Color4	
		040-047	Color5	
		048-054	Color6	
		055-061	Color7	
		062-069	Color8	
		070-076	Color9	
		077-084	Color10	
		085-091	Color11	
		092-099	Color12	
		100-106	Color13	
		107-113	Color14	
114-121	Color15			
122-128	Color16			
129-136	Color17			
137-143	Color18			
144-151	Color19			

	152-158	Color20	
	159-165	Color21	
	166-173	Color22	
	174-180	Color23	
	181-188	Color24	
	189-195	Color25	
	196-203	Color26	
	204-210	Color27	
	211-217	Color28	
	218-225	Color29	
	226-232	Color30	
	233-240	Color31	
	241-247	Color32	
	248-255	Color33	
5	000-255	MASTER DIMMER (coarse) 0 → 100%	
6	000-255	MASTER DIMMER (fine) 0 → 100%	
7	000-255	STROBE DURATION	
		STROBE SPEED	
8	000-006	No strobe	
	007-255	SPEED (slow → fast)	<i>pixel 1</i>
		STROBE EFFECTS	
9	000-005	No effect	
	006-050	Ramp up	
	051-100	Ramp down	
	101-150	Ramp up-down	
	151-200	Lightning	
	201-255	Random	
		EFFECT MACROS	<i>RGB macros use 32pixels</i>
	000-039	No function	
	040-047	RGB Macro 1	
	048-055	RGB Macro 2	
	056-063	RGB Macro 3	
	064-071	RGB Macro 4	
	072-079	RGB Macro 5	
	080-087	RGB Macro 6	
	088-095	RGB Macro 7	
	096-103	RGB Macro 8	
	104-111	RGB Macro 9	
	112-119	RGB Macro 10	
	120-127	RGB Macro 11	
	128-135	RGB Macro 12	
10	136-143	RGB Macro 13	
	144-151	RGB Macro 14	
	152-159	RGB Macro 15	
	160-167	RGB Macro 16	
	168-175	RGB Macro 17	
	176-183	RGB Macro 18	
	184-191	RGB Macro 19	
	192-199	RGB Macro 20	
	200-207	RGB Macro 21	
	208-215	RGB Macro 22	
	216-223	RGB Macro 23	
	224-231	RGB Macro 24	
	232-239	RGB Macro 25	
	240-247	RGB Macro 26	
	248-255	RGB Macro 27	
		MACRO SPEED	
11	000-004	STOP (waiting at first step)	
	005-127	SPEED L→R: SLOW to FAST	
	128-132	STOP (waiting at last step)	
	133-255	SPEED R→L: SLOW to FAST	
12	000-255	FADE EFFECT (zero → max)	

CONTROLS FOR WHITE ZONE	13	000-255	MASTER DIMMER (coarse) 0 → 100%		
	14	000-255	MASTER DIMMER (fine) 0 → 100%		
	15	000-255	STROBE DURATION		
	16			STROBE SPEED	
		000-006	No strobe		
		007-255	SPEED (slow → fast)		<i>pixel 2</i>
	17			STROBE EFFECTS	
		000-005	No effect		
		006-050	Ramp up		
		051-100	Ramp down		
		101-150	Ramp up-down		
		151-200	Lightning		
		201-255	Random		
	18			EFFECT MACROS	<i>WHITE macros use 16pixels</i>
		000-090	No function		
		091-105	WHITE Macro 1		
		106-120	WHITE Macro 2		
		121-135	WHITE Macro 3		
		136-150	WHITE Macro 4		
		151-165	WHITE Macro 5		
166-180		WHITE Macro 6			
181-195		WHITE Macro 7			
196-210		WHITE Macro 8			
211-225		WHITE Macro 9			
226-240		WHITE Macro 10			
19			MACRO SPEED		
	000-004	STOP (waiting at first step)			
	005-127	SPEED L→R: SLOW to FAST			
	128-132	STOP (waiting at last step)			
20	133-255	SPEED R→L: SLOW to FAST			
	000-255	FADE EFFECT (zero → max)			
21			FUNCTION CHANNEL		
	000-005	No function			
	006-010	DIMMER CURVE: LINEAR		<i>3 seconds delay</i>	
	011-015	DIMMER CURVE: SQUARE		<i>3 seconds delay</i>	
	016-020	DIMMER CURVE: INV. SQUARE		<i>3 seconds delay</i>	
	021-025	DIMMER CURVE: S-CURVE		<i>3 seconds delay</i>	
	026-030	No function			
	031-035	DIMMER SPEED: FAST		<i>3 seconds delay</i>	
	036-040	DIMMER SPEED: SLOW		<i>3 seconds delay</i>	
	041-045	No function			
	046-050	PIXEL ORDER: NORMAL		<i>3 seconds delay</i>	
	051-055	PIXEL ORDER: INVERSED		<i>3 seconds delay</i>	
	056-065	No function			
	066-070	LED PWM Frequency: 3600Hz		<i>3 seconds delay</i>	
	071-075	LED PWM Frequency: 4800Hz		<i>3 seconds delay</i>	
	076-080	LED PWM Frequency: 7200Hz		<i>3 seconds delay</i>	
	081-085	LED PWM Frequency: 12000Hz		<i>3 seconds delay</i>	
086-255	No function				

39CH LAYOUT

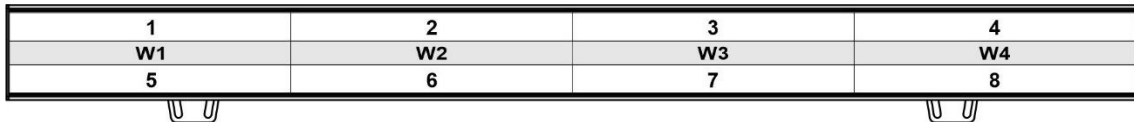

39 CH	VALUE	FUNCTION	REMARKS	
CONTROLS FOR RGB ZONES	1	000-255	RED1	
	2	000-255	GREEN1	
	3	000-255	BLUE1	
	4	000-255	RED2	
	5	000-255	GREEN2	
	6	000-255	BLUE2	
	7	000-255	RED3	
	8	000-255	GREEN3	
	9	000-255	BLUE3	
	10	000-255	RED4	
	11	000-255	GREEN4	
	12	000-255	BLUE4	
	13	000-255	RED5	
	14	000-255	GREEN5	
	15	000-255	BLUE5	
	16	000-255	RED6	
	17	000-255	GREEN6	
	18	000-255	BLUE6	
	19	000-255	RED7	
	20	000-255	GREEN7	
	21	000-255	BLUE7	
	22	000-255	RED8	
	23	000-255	GREEN8	
	24	000-255	BLUE8	
	25	000-255	MASTER DIMMER (coarse) 0 → 100%	
	26	000-255	MASTER DIMMER (fine) 0 → 100%	
	27	000-255	STROBE DURATION	
28		STROBE SPEED		
	000-006	No strobe		
	007-255	SPEED (slow → fast)		
29		STROBE EFFECTS		
	000-005	No effect		
	006-050	Ramp up		
	051-100	Ramp down		
	101-150	Ramp up-down		
	151-200	Lightning		
	201-255	Random		
WHITE ZONE	30	000-255	WHITE 1	
	31	000-255	WHITE 2	
	32	000-255	WHITE 3	
	33	000-255	WHITE 4	
	34	000-255	MASTER DIMMER (coarse) 0 → 100%	
	35	000-255	MASTER DIMMER (fine) 0 → 100%	
	36	000-255	STROBE DURATION	
	37		STROBE SPEED	
		000-006	No strobe	
		007-255	SPEED (slow → fast)	
	38		STROBE EFFECTS	
		000-005	No effect	
		006-050	Ramp up	
		051-100	Ramp down	
		101-150	Ramp up-down	
151-200		Lightning		
201-255		Random		

		FUNCTION CHANNEL	
39	000-005	No function	
	006-010	DIMMER CURVE: LINEAR	3 seconds delay
	011-015	DIMMER CURVE: SQUARE	3 seconds delay
	016-020	DIMMER CURVE: INV. SQUARE	3 seconds delay
	021-025	DIMMER CURVE: S-CURVE	3 seconds delay
	026-030	No function	
	031-035	DIMMER SPEED: FAST	3 seconds delay
	036-040	DIMMER SPEED: SLOW	3 seconds delay
	041-045	No function	
	046-050	PIXEL ORDER: NORMAL	3 seconds delay
	051-055	PIXEL ORDER: INVERSED	3 seconds delay
	056-065	No function	
	066-070	LED PWM Frequency: 3600Hz	3 seconds delay
	071-075	LED PWM Frequency: 4800Hz	3 seconds delay
	076-080	LED PWM Frequency: 7200Hz	3 seconds delay
	081-085	LED PWM Frequency: 12000Hz	3 seconds delay
086-255	No function		

DMX CHARTS for pure PIXEL MAPPING

Several extended DMX modes: the perfect choice while used with media servers and consoles with pixel mapping possibilities. **The new 123CH mode is the most adapted for easy programming of big shows!**

17CH LAYOUT

1	2	3	4
W1	W2	W3	W4
1	2	3	4

33CH LAYOUT

1	2	3	4	5	6	7	8
W1	W2	W3	W4	W5	W6	W7	W8
1	2	3	4	5	6	7	8

65CH LAYOUT

1	2	3	4	5	6	7	8	9	10	11	12	13	14	15	16
W1	W2	W3	W4	W5	W6	W7	W8	W9	W10	W11	W12	W13	W14	W15	W16
1	2	3	4	5	6	7	8	9	10	11	12	13	14	15	16

113CH + 123CH LAYOUT

1	2	3	4	5	6	7	8	9	10	11	12	13	14	15	16
W1	W2	W3	W4	W5	W6	W7	W8	W9	W10	W11	W12	W13	W14	W15	W16
17	18	19	20	21	22	23	24	25	26	27	28	29	30	31	32

17CH	33CH	65CH	113CH	123CH	VALUE	FUNCTION	REMARKS
PIXEL CONTROL							
1	1	1	1	1	000-255	RED1	
2	2	2	2	2	000-255	GREEN1	
3	3	3	3	3	000-255	BLUE1	
4	4	4	4	4	000-255	RED2	
5	5	5	5	5	000-255	GREEN2	
6	6	6	6	6	000-255	BLUE2	
7	7	7	7	7	000-255	RED3	
8	8	8	8	8	000-255	GREEN3	
9	9	9	9	9	000-255	BLUE3	
10	10	10	10	10	000-255	RED4	

11	11	11	11	11	000-255	GREEN4	
12	12	12	12	12	000-255	BLUE4	
	13	13	13	13	000-255	RED5	
	14	14	14	14	000-255	GREEN5	
	15	15	15	15	000-255	BLUE5	
	16	16	16	16	000-255	RED6	
	17	17	17	17	000-255	GREEN6	
	18	18	18	18	000-255	BLUE6	
	19	19	19	19	000-255	RED7	
	20	20	20	20	000-255	GREEN7	
	21	21	21	21	000-255	BLUE7	
	22	22	22	22	000-255	RED8	
	23	23	23	23	000-255	GREEN8	
	24	24	24	24	000-255	BLUE8	
	25	25	25	25	000-255	RED9	
	26	26	26	26	000-255	GREEN9	
	27	27	27	27	000-255	BLUE9	
	28	28	28	28	000-255	RED10	
	29	29	29	29	000-255	GREEN10	
	30	30	30	30	000-255	BLUE10	
	31	31	31	31	000-255	RED11	
	32	32	32	32	000-255	GREEN11	
	33	33	33	33	000-255	BLUE11	
	34	34	34	34	000-255	RED12	
	35	35	35	35	000-255	GREEN12	
	36	36	36	36	000-255	BLUE12	
	37	37	37	37	000-255	RED13	
	38	38	38	38	000-255	GREEN13	
	39	39	39	39	000-255	BLUE13	
	40	40	40	40	000-255	RED14	
	41	41	41	41	000-255	GREEN14	
	42	42	42	42	000-255	BLUE14	
	43	43	43	43	000-255	RED15	
	44	44	44	44	000-255	GREEN15	
	45	45	45	45	000-255	BLUE15	
	46	46	46	46	000-255	RED16	
	47	47	47	47	000-255	GREEN16	
	48	48	48	48	000-255	BLUE16	
	49	49	49	49	000-255	RED17	
	50	50	50	50	000-255	GREEN17	
	51	51	51	51	000-255	BLUE17	
	52	52	52	52	000-255	RED18	
	53	53	53	53	000-255	GREEN18	
	54	54	54	54	000-255	BLUE18	
	55	55	55	55	000-255	RED19	
	56	56	56	56	000-255	GREEN19	
	57	57	57	57	000-255	BLUE19	
	58	58	58	58	000-255	RED20	
	59	59	59	59	000-255	GREEN20	
	60	60	60	60	000-255	BLUE20	
	61	61	61	61	000-255	RED21	
	62	62	62	62	000-255	GREEN21	
	63	63	63	63	000-255	BLUE21	
	64	64	64	64	000-255	RED22	
	65	65	65	65	000-255	GREEN22	
	66	66	66	66	000-255	BLUE22	
	67	67	67	67	000-255	RED23	
	68	68	68	68	000-255	GREEN23	
	69	69	69	69	000-255	BLUE23	
	70	70	70	70	000-255	RED24	
	71	71	71	71	000-255	GREEN24	
	72	72	72	72	000-255	BLUE24	

			73	73	000-255	RED25			
			74	74	000-255	GREEN25			
			75	75	000-255	BLUE25			
			76	76	000-255	RED26			
			77	77	000-255	GREEN26			
			78	78	000-255	BLUE26			
			79	79	000-255	RED27			
			80	80	000-255	GREEN27			
			81	81	000-255	BLUE27			
			82	82	000-255	RED28			
			83	83	000-255	GREEN28			
			84	84	000-255	BLUE28			
			85	85	000-255	RED29			
			86	86	000-255	GREEN29			
			87	87	000-255	BLUE29			
			88	88	000-255	RED30			
			89	89	000-255	GREEN30			
			90	90	000-255	BLUE30			
			91	91	000-255	RED31			
			92	92	000-255	GREEN31			
			93	93	000-255	BLUE31			
			94	94	000-255	RED32			
			95	95	000-255	GREEN32			
			96	96	000-255	BLUE32			
				97	000-255	MASTER DIMMER (coarse)	0→ 100%		
				98	000-255	MASTER DIMMER (fine)	0→ 100%		
				99	000-255	STROBE DURATION			
						STROBE SPEED			
				100	000-006	No strobe			
					007-255	SPEED (slow → fast)	pixel 1		
						STROBE EFFECTS			
					000-005	No effect			
					006-050	Ramp up			
					051-100	Ramp down			
					101-150	Ramp up-down			
					151-200	Lightning			
					201-255	Random			
13	25	49	97	102	000-255	WHITE 1			
14	26	50	98	103	000-255	WHITE 2			
15	27	51	99	104	000-255	WHITE 3			
16	28	52	100	105	000-255	WHITE 4			
			29	53	101	106	000-255	WHITE 5	
			30	54	102	107	000-255	WHITE 6	
			31	55	103	108	000-255	WHITE 7	
			32	56	104	109	000-255	WHITE 8	
				57	105	110	000-255	WHITE 9	
				58	106	111	000-255	WHITE 10	
				59	107	112	000-255	WHITE 11	
				60	108	113	000-255	WHITE 12	
				61	109	114	000-255	WHITE 13	
				62	110	115	000-255	WHITE 14	
				63	111	116	000-255	WHITE 15	
				64	112	117	000-255	WHITE 16	
					118	000-255	MASTER DIMMER (coarse)	0→ 100%	
					119	000-255	MASTER DIMMER (fine)	0→ 100%	
				120	000-255	STROBE DURATION			
						STROBE SPEED			
				121	000-006	No strobe			
					007-255	SPEED (slow → fast)	pixel 2		
						STROBE EFFECTS			
				122	000-005	No effect			
					006-050	Ramp up			

					051-100	Ramp down	
					101-150	Ramp up-down	
					151-200	Lightning	
					201-255	Random	
					FUNCTION CHANNEL		
					000-005	No function	
					006-010	DIMMER CURVE: LINEAR	<i>3 seconds delay</i>
					011-015	DIMMER CURVE: SQUARE	<i>3 seconds delay</i>
					016-020	DIMMER CURVE: INV. SQUARE	<i>3 seconds delay</i>
					021-025	DIMMER CURVE: S-CURVE	<i>3 seconds delay</i>
					026-030	No function	
					031-035	DIMMER SPEED: FAST	<i>3 seconds delay</i>
					036-040	DIMMER SPEED: SLOW	<i>3 seconds delay</i>
					041-045	No function	
					046-050	PIXEL ORDER: NORMAL	<i>3 seconds delay</i>
					051-055	PIXEL ORDER: INVERSED	<i>3 seconds delay</i>
					056-065	No function	
					066-070	LED PWM Frequency: 3600Hz	<i>3 seconds delay</i>
					071-075	LED PWM Frequency: 4800Hz	<i>3 seconds delay</i>
					076-080	LED PWM Frequency: 7200Hz	<i>3 seconds delay</i>
					081-085	LED PWM Frequency: 12000Hz	<i>3 seconds delay</i>
					086-255	No function	

DMX CHARTS for combined PIXEL MAPPING AND MACRO SUPPORT

The best choice if you want to use the BTX-LIGHTSTRIKE with media servers and consoles with pixel mapping possibilities but you also want to have access to the easy internal macros: best of both worlds ...

33CH FULL LAYOUT

1	2	3	4
W1	W2	W3	W4
1	2	3	4

49CH FULL LAYOUT

1	2	3	4	5	6	7	8
W1	W2	W3	W4	W5	W6	W7	W8
1	2	3	4	5	6	7	8

81CH FULL LAYOUT

1	2	3	4	5	6	7	8	9	10	11	12	13	14	15	16
W1	W2	W3	W4	W5	W6	W7	W8	W9	W10	W11	W12	W13	W14	W15	W16
1	2	3	4	5	6	7	8	9	10	11	12	13	14	15	16

33CH	49CH	81CH	VALUE	FUNCTION	REMARKS
FULL CONTROL					
1	1	1	000-255	RED1	
2	2	2	000-255	GREEN1	
3	3	3	000-255	BLUE1	
4	4	4	000-255	RED2	
5	5	5	000-255	GREEN2	
6	6	6	000-255	BLUE2	
7	7	7	000-255	RED3	
8	8	8	000-255	GREEN3	
9	9	9	000-255	BLUE3	
10	10	10	000-255	RED4	
11	11	11	000-255	GREEN4	
12	12	12	000-255	BLUE4	
	13	13	000-255	RED5	
	14	14	000-255	GREEN5	

	15	15	000-255	BLUE5	
	16	16	000-255	RED6	
	17	17	000-255	GREEN6	
	18	18	000-255	BLUE6	
	19	19	000-255	RED7	
	20	20	000-255	GREEN7	
	21	21	000-255	BLUE7	
	22	22	000-255	RED8	
	23	23	000-255	GREEN8	
	24	24	000-255	BLUE8	
		25	000-255	RED9	
		26	000-255	GREEN9	
		27	000-255	BLUE9	
		28	000-255	RED10	
		29	000-255	GREEN10	
		30	000-255	BLUE10	
		31	000-255	RED11	
		32	000-255	GREEN11	
		33	000-255	BLUE11	
		34	000-255	RED12	
		35	000-255	GREEN12	
		36	000-255	BLUE12	
		37	000-255	RED13	
		38	000-255	GREEN13	
		39	000-255	BLUE13	
		40	000-255	RED14	
		41	000-255	GREEN14	
		42	000-255	BLUE14	
		43	000-255	RED15	
		44	000-255	GREEN15	
		45	000-255	BLUE15	
		46	000-255	RED16	
		47	000-255	GREEN16	
		48	000-255	BLUE16	
13	25	49	000-255	MASTER DIMMER (coarse)	0 → 100%
14	26	50	000-255	MASTER DIMMER (fine)	0 → 100%
15	27	51	000-255	STROBE DURATION	
				STROBE SPEED	
16	28	52	000-006	No strobe	
			007-255	SPEED (slow → fast)	pixel 1
				STROBE EFFECTS	
17	29	53	000-005	No effect	
			006-050	Ramp up	
			051-100	Ramp down	
			101-150	Ramp up-down	
			151-200	Lightning	
			201-255	Random	
				EFFECT MACROS	RGB macros use 32pixels
18	30	54	000-039	No function	
			040-047	RGB Macro 1	
			048-055	RGB Macro 2	
			056-063	RGB Macro 3	
			064-071	RGB Macro 4	
			072-079	RGB Macro 5	
			080-087	RGB Macro 6	
			088-095	RGB Macro 7	
			096-103	RGB Macro 8	
			104-111	RGB Macro 9	
			112-119	RGB Macro 10	
			120-127	RGB Macro 11	
			128-135	RGB Macro 12	
			136-143	RGB Macro 13	
			144-151	RGB Macro 14	
			152-159	RGB Macro 15	
			160-167	RGB Macro 16	

			168-175	RGB Macro 17	
			176-183	RGB Macro 18	
			184-191	RGB Macro 19	
			192-199	RGB Macro 20	
			200-207	RGB Macro 21	
			208-215	RGB Macro 22	
			216-223	RGB Macro 23	
			224-231	RGB Macro 24	
			232-239	RGB Macro 25	
			240-247	RGB Macro 26	
			248-255	RGB Macro 27	
				MACRO SPEED	
19	31	55	000-004	STOP (waiting at first step)	
			005-127	SPEED L→R: SLOW to FAST	
			128-132	STOP (waiting at last step)	
			133-255	SPEED R→L: SLOW to FAST	
20	32	56	000-255	FADE EFFECT (zero → max)	
21	33	57	000-255	WHITE 1	
22	34	58	000-255	WHITE 2	
23	35	59	000-255	WHITE 3	
24	36	60	000-255	WHITE 4	
	37	61	000-255	WHITE 5	
	38	62	000-255	WHITE 6	
	39	63	000-255	WHITE 7	
	40	64	000-255	WHITE 8	
		65	000-255	WHITE 9	
		66	000-255	WHITE 10	
		67	000-255	WHITE 11	
		68	000-255	WHITE 12	
		69	000-255	WHITE 13	
		70	000-255	WHITE 14	
		71	000-255	WHITE 15	
		72	000-255	WHITE 16	
25	41	73	000-255	MASTER DIMMER (coarse)	0→ 100%
26	42	74	000-255	MASTER DIMMER (fine)	0→ 100%
27	43	75	000-255	STROBE DURATION	
				STROBE SPEED	
28	44	76	000-006	No strobe	
			007-255	SPEED (slow → fast)	pixel 2
				STROBE EFFECTS	
29	45	77	000-005	No effect	
			006-050	Ramp up	
			051-100	Ramp down	
			101-150	Ramp up-down	
			151-200	Lightning	
			201-255	Random	
				EFFECT MACROS	WHITE macros use 16pixels
30	46	78	000-090	No function	
			091-105	WHITE Macro 1	
			106-120	WHITE Macro 2	
			121-135	WHITE Macro 3	
			136-150	WHITE Macro 4	
			151-165	WHITE Macro 5	
			166-180	WHITE Macro 6	
			181-195	WHITE Macro 7	
			196-210	WHITE Macro 8	
			211-225	WHITE Macro 9	
			226-240	WHITE Macro 10	
			241-255	WHITE Macro 11	
				MACRO SPEED	
31	47	79	000-004	STOP (waiting at first step)	
			005-127	SPEED L→R: SLOW to FAST	
			128-132	STOP (waiting at last step)	
			133-255	SPEED R→L: SLOW to FAST	
32	48	80	000-255	FADE EFFECT (zero → max)	

			FUNCTION CHANNEL		
33	49	81	000-005	No function	
			006-010	DIMMER CURVE: LINEAR	3 seconds delay
			011-015	DIMMER CURVE: SQUARE	3 seconds delay
			016-020	DIMMER CURVE: INV. SQUARE	3 seconds delay
			021-025	DIMMER CURVE: S-CURVE	3 seconds delay
			026-030	No function	
			031-035	DIMMER SPEED: FAST	3 seconds delay
			036-040	DIMMER SPEED: SLOW	3 seconds delay
			041-045	No function	
			046-050	PIXEL ORDER: NORMAL	3 seconds delay
			051-055	PIXEL ORDER: INVERSED	3 seconds delay
			056-065	No function	
			066-070	LED PWM Frequency: 3600Hz	3 seconds delay
			071-075	LED PWM Frequency: 4800Hz	3 seconds delay
			076-080	LED PWM Frequency: 7200Hz	3 seconds delay
			081-085	LED PWM Frequency: 12000Hz	3 seconds delay
			086-255	No function	

RDM FUNCTIONS / REMOTE SETUP

RDM means “Remote Device Management” (control the unit from a distance). This projector works with a brief set of RDM-functions which means that it can setup a bi-directional communication with an RDM-compatible DMX-controller. Some of these functions are briefly explained below, others will be added in the future.

- The DMX-controller sends out a “discovery command”, all RDM devices respond and send their unique device ID.
- The DMX-controller asks each RDM device for some basic data so it knows which devices are connected. The projector will respond:
 - **Device name:** BTX-LIGHTSTRIKE
 - **Manufacturer:** Briteq®
 - **Category:** LED Dimmer
 - **Firmware:** x.x.x.x (firmware version of the projector)
 - **DMX address:** xxx (current DMX start address of the projector)
 - **DMX footprint:** xx (number of DMX-channels used by the projector)
 - **Personality:** xx (current personality or DMX-working mode used by the projectors)
- The DMX-controller can send certain commands to each RDM device which allow remote setup of the units. Thanks to this the projectors can be setup remotely.

The following functions can be managed remotely:

No longer need to take a ladder and set all units one by one!

- **DMX START ADDRESS:** The start address can be set remotely from 001 to xxx.
- **PERSONALITY:** The DMX working mode (DMX-chart) can be set remotely.

These 2 functions make it possible to prepare a complete DMX-patch of all projectors on the DMX-controller and send these data to all projectors at once. More functions will be added later.

Further list of all supported RDM PIDs:

RDM Parameter IDs	
DISC_UN_MUTE	0x0003
DISC_UNIQUE_BRANCH	0x0001
DISC_MUTE	0x0002
DEVICE_INFO	0x0060
MANUFACTURER_LABEL	0x0081
DEVICE_LABEL	0x0082
DEVICE_MODEL_DESCRIPTION	0x0080
SOFTWARE_VERSION_LABEL	0x00C0
SUPPORTED_PARAMETERS	0x0050
STATUS_MESSAGES	0x0030
DMX_PERSONALITY	0x00E0
DMX_PERSONALITY_DESCRIPTION	0x00E1
DMX_START_ADDRESS	0x00F0

RESET_DEVICE	0x1001
IDENTIFY_DEVICE	0x1000
SENSOR_DEFINITION	0x0200
SENSOR_VALUE	0x0201
FACTORY_DEFAULTS	0x0090
DEVICE_HOURS	0x0040
RDM_ERROR_LOG	0xA018

MAINTENANCE

- Make sure the area below the installation place is free from unwanted persons during servicing.
- Switch off the unit, unplug the mains cable and wait until the unit has been cooled down.

During inspection the following points should be checked:

- All screws used for installing the device and any of its parts should be tightly fastened and may not be corroded.
- Housings, fixations and installations spots (ceiling, truss, suspensions) should be totally free from any deformation.
- When an optical lens is visibly damaged due to cracks or deep scratches, it must be replaced.
- The mains cables must be in impeccable condition and should be replaced immediately when even a small problem is detected.
- In order to protect the device from overheat the cooling fans (if any) and ventilation openings should be cleaned monthly.
- The cleaning of internal and external optical lenses and/or mirrors must be carried out periodically to optimize light output. Cleaning frequency depends on the environment in which the fixture operates: damp, smoky or particularly dirty surroundings can cause greater accumulation of dirt on the unit's optics.
 - Clean with a soft cloth using normal glass cleaning products.
 - Always dry the parts carefully.

Attention: We strongly recommend internal cleaning to be carried out by qualified technician!

SPECIFICATIONS

This unit is radio-interference suppressed. This product meets the requirements of the current European and national guidelines. Conformity has been established and the relevant statements and documents have been deposited by the manufacturer.

Power supply	AC 100-240V, 50/60Hz
Power consumption	350Watt max (all pixels @ 100%)
Power factor (PF)	0,95
Power in/out linking capacity	9A @ 240Vac * 5A @ 100Vac
Fuse	T6,3A / 250V
Power connections	PowerCON compatible connector
Protection rating	IP20
LEDs	672pcs 0,3W RGB + 112pcs 3W CW
Individual LED zones	32 RGB-zones + 16 CW-zones
Supported control signals:	DMX512+RDM, Art-Net™, sACN
DMX connections	3pin XLR male + 3pin XLR female
DMX channel modes	12 modes: 6 → 123 channels
Beam angle	116°
LED refresh rate	3600Hz → 12000Hz
Enclosure temperature (T_a: 40°C)	Surface: 65°C max.
Dimensions LxWxD (mm)	1000x84x81 (with omega bases installed, see drawing)
Dimensions LxWxD (mm)	1000x84x102 (with standard brackets installed, see drawing)
Weight (kg)	5,5

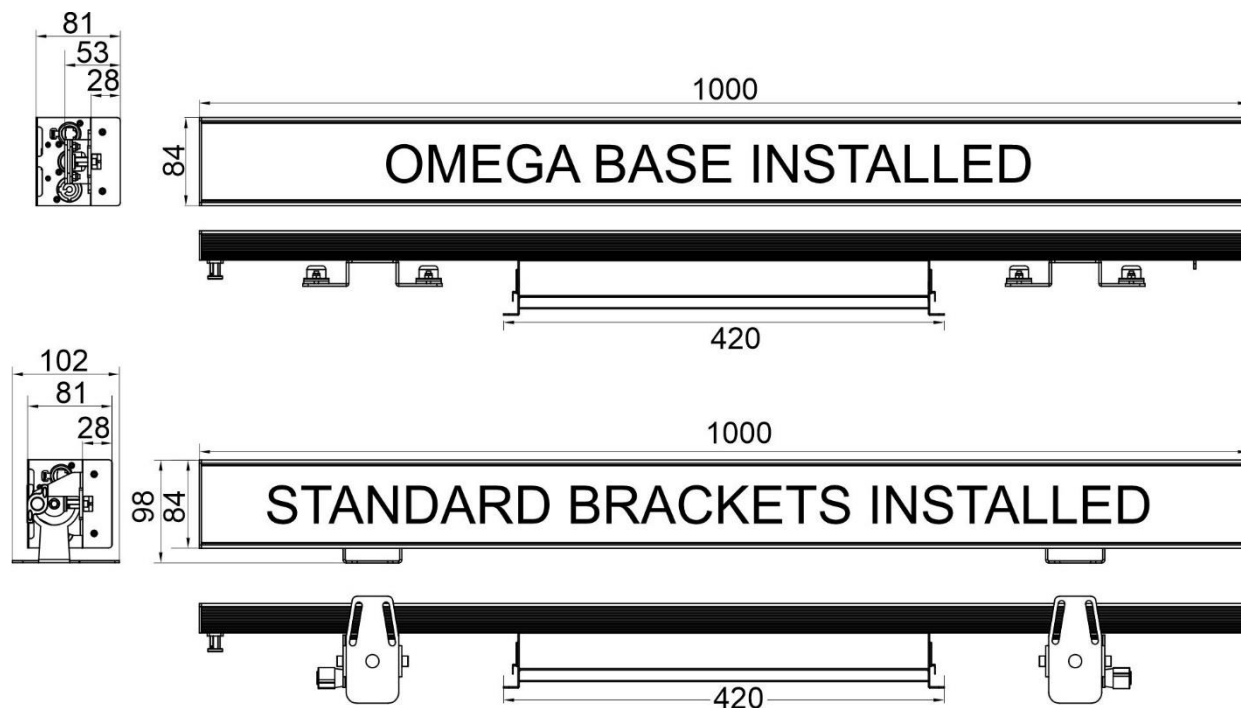

LUX CHART

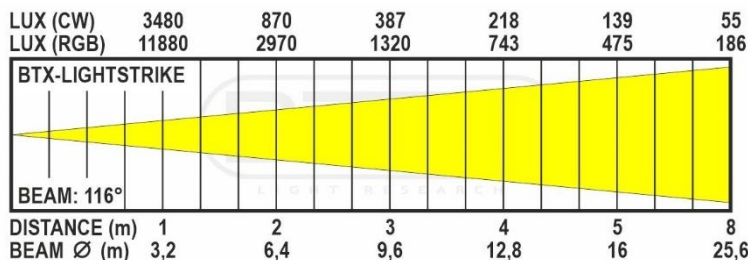

The information might be modified without prior notice

You can download the latest version of this user manual on our website: www.briteq-lighting.com



MAILING LIST

EN: Subscribe today to our mailing list for the latest product news!

FR: Inscrivez-vous à notre liste de distribution si vous souhaitez suivre l'actualité de nos produits!

NL: Abonneer je vandaag nog op onze mailinglijst en ontvang ons laatste product nieuws!

DE: Abonnieren Sie unseren Newsletter und erhalten Sie aktuelle Produktinformationen!

ES: Suscríbete hoy a nuestra lista de correo para recibir las últimas noticias!

PT: Inscreva-se hoje na nossa mailing list para estar a par das últimas notícias!

WWW.BRITEQ-LIGHTING.COM

Copyright © 2023 by BEGLEC NV

't Hofveld 2C ~ B1702 Groot-Bijgaarden ~ Belgium

Reproduction or publication of the content in any manner, without express permission of the publisher, is prohibited.